



KS Series

Karaoke Loudspeaker System
卡拉OK系統

縱情歡唱 盡享歡歌

Sing wantonly, enjoy singing



技精于博 專注于聲



THE BEST OF BEST.....

- ❶ 告別傳統、自我創新、這是對KS系列最好的形容。每項新產品的面世，總是因為舊的產品中存在某些缺陷或局限性，而不能完全滿足用戶的需求。但通過創新概念而開發的KS系列一改傳統的卡拉OK音箱的設計格局，馬上為工程商提供了最佳的解決方法。
- ❷ 全新開發的KS系列採用了一款獨特的三角型恒定指向號角，並排在兩祇低音之間，另到高頻和低頻的波前幹擾降至最低。這樣的設計使聲音更有效地控制中高頻頻率的定向。這樣聲音會導向演唱者，而不會投于牆壁、天花板或地面上而產生回響，很好地解決了傳統卡拉OK揚聲器和話筒的嘯叫問題。
- ❸ Leave tradition, self innovate, this best describe KS series. Each new products Come out, always due to the defect or limit or old model can't meet users. But the new KS series developed through creative concept change the traditional karaoke speaker structure, provide the best solution to project man.
- ❹ The new KS series contains a unique triangle firm directing horn, placed between 2 woofers, lowest the interference of HF and LF in front of wave. This design effectively control M/H frequency direction. The sound will go toward singer, but not the wall, ceiling or ground to make resound, best solve the interference between speaker and microphone of traditional karaoke speaker.

Enclosure Design 箱體設計

選用高密度板材制造的箱體配合博聲音響的獨特箱體作工藝，使得箱體的密封更佳，有效抑制多餘的震蕩和諧振，令箱體的諧振抗與分頻阻抗達到最佳配合。

High density wood board adding BOB audio's unique making skill, make the cabinet better on sealing, better limit the extra vibration and resonance, so the cabinet's resonance resistant best matches the crossover resistant.



Asymmetry Firm

Directing Horn

不對稱恒定指向性輻射號角

為了使一些量販式KTV的較大房間裏不用去安裝和裝修格調格格不入的PA音箱，博聲音響製造了KS-3和KS-4兩款體形細小功率強大的純KTV音箱去配合使用。為了滿足KTV房間的要求，盡可能縮小音箱的體積，KS-3和KS-4採用了一款博聲音響擁有專利技術的不對稱三角圖形恒定指向性號角，並排在兩低音之間，令到高频和低频的波前干涉減至最低。這樣的設計更有效地控制中高频的頻率定向。聲音就會導向演唱者，而不會投向牆壁天花或者地面上產生多餘的回響，很好地解決了傳統KTV揚聲器和話筒的嘯叫問題。

不對稱恒定指向性輻射號角的技術說明：

三角形的不對稱恒定指向性輻射號角最大的特點就是它的垂直覆蓋面是不對稱的輻射角度，號角軸上方的角度是10度，軸下方角度是50度。但是水平的角度覆蓋面就很寬，有110度。這樣的好處是明顯的，水平角度很寬很容易融合左右聲場，令到整個房間都充滿能量。而垂直向上角度只有10度。號角發出的聲音就會很少投射到天花上面，大部份的能量都投射到下面。當所有能量都集中地擴散到演唱者周圍，演唱者很容易了解到自己的演唱，而其它方向只有較小的聲能量，特別是天花。所以會有效地減少房間的雜音和聲反射，降低話筒的嘯叫機率。

In order to avoid installing some wrong PA speaker into big KTV room, BOB AUDIO make out KS-3 and KS-4, small and high power KTV speaker. To meet the KTV room size, we reduce the speaker volume, KS-3 and KS-4 is built in a BOB AUDIO's patented asymmetry triangle firm directing horn, placed between 2 woofers, lowest the interference of HF and LF in front of wave. This design effectively control M/H frequency direction. The sound will go toward singer, but not the wall, ceiling or ground to make resound, best solve the interference between speaker and microphone of traditional karaoke speaker.

Asymmetry firm directing horn introduce: (please refer to the old picture or horn) the biggest feature of this horn is the vertical side is asymmetry, the upper angle is 10, down is 50. But the horizontal angle is wide, 110. The advantage is, wide horizontal angle can go into left and right sound channel, so the power fill the room. The upper angle of vertical is only 10, the sound seldom go to ceiling, most go downward. All the sound goes to singer, he/she can know about the singing, there is only light sound in other direction, especially ceiling. This can reduce the noise and sound reflect, also to reduce the interference between speaker and microphone.

2 Way

Full Range

兩路全頻設計

全新挑選的紙盆高频驅動器和沫邊低频驅動器頻響銜接平滑，沒有明顯的分頻點失真效應。經過精細的調整頻網絡系統使高低頻的相位同步，得到更符合聽覺的平滑頻率響應和KTV音箱好唱易唱的特色。

The new paper cone HF unit and LF unit link up frequency smoothly, no big crossover distortion. The optimized network make the H/L frequency phase synchro, make out a more suitable smooth frequency and a easy and good to sing KTV speaker.

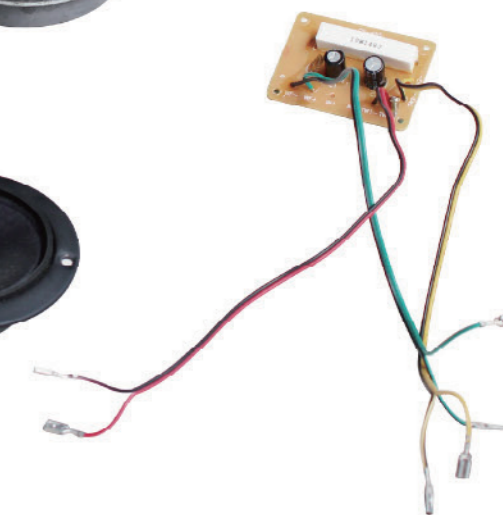
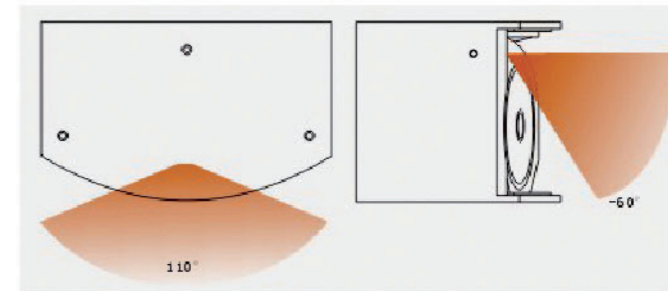
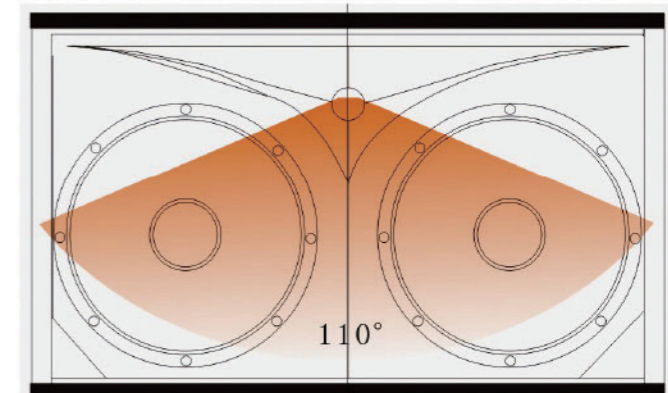

Convenient To Install 安裝簡便

KS系列采用了全世界都通用的標準KTV吊裝架，容易採購、安裝簡便，祇需要固定好安裝螺絲，調整好投射角度就完成所有安裝工作。

KS series is designed with world standard ktv flying frame, easy to buy, simple to install. Just firm the screw and adjust the shooting angle.

Dsp Combine Amplifier DSP合并式功放

能够完美地呈现卡拉OK的所有細節，除了有好的音箱當然還需要一臺好的卡拉OK功放，為了營造歌唱的多種需求，采用先進的DSP數碼處理集成電路，輸出柔美的卡拉OK演唱效果，讓我們的卡拉OK功放能為您提供更高的演唱享受。

To show the details of karaoke perfectly, you need a good amplifier besides a good speaker. To meet different requirement, we use advanced DSP digital IC, make out soft and nice karaoke singing, our karaoke amplifier will let you enjoy the singing.



- 1 高輸出350w x 2通道
350w*2 high power output
- 2 Dsp效果處理器
Dsp processor
- 3 Fbk防嘯叫功能
Fbk antit howling
- 4 Exp激勵功能
Exp inspirit function
- 5 6種音樂模式可選
6 Music modes
- 6 6種麥克風模式可選
6 Microphones modes
- 7 超低信號輸出
Lf signal output
- 8 三鍵音樂升降調選擇
3 Bottons adjusting music tone
- 9 可調節回聲和回響效果
Resound and resonance adjustable
- 10 紅外線遙控全部功能
Infrared remote control all the function
- 11 開機和最大音量設置
Power on and max volumn setting
- 12 7段麥克風EQ調節
7 Groups of microphone eq adjustment
- 13 8組人聲效果預設模式及4組自定義模式，更多選擇
8group human voice effect preset and 4 groups customize
- 14 外接有源遙控器插座line control
Extra active remote control plug line control
- 15 前後級分離設計
Front and back amplifier seperate
- 16 Usb接口連接pc輕鬆設置系統
Usb connect to pc